

# TLV5623C, TLV5623I

## 2.7-V TO 5.5-V LOW POWER 8-BIT DIGITAL-TO-ANALOG CONVERTERS WITH POWER DOWN

SLAS231B – JUNE 1999 – REVISED APRIL 2004

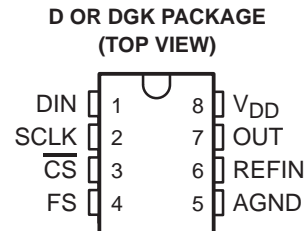
- **8-Bit Voltage Output DAC**
- **Programmable Settling Time vs Power Consumption**  
     3  $\mu$ s in Fast Mode  
     9  $\mu$ s in Slow Mode
- **Ultra Low Power Consumption:**  
     900  $\mu$ W Typ in Slow Mode at 3 V  
     2.1 mW Typ in Fast Mode at 3 V
- **Differential Nonlinearity . . . <0.2 LSB**
- **Compatible With TMS320 and SPI Serial Ports**
- **Power-Down Mode**
- **Buffered High-Impedance Reference Input**
- **Monotonic Over Temperature**
- **Available in MSOP Package**

### applications

- Digital Servo Control Loops
- Digital Offset and Gain Adjustment
- Industrial Process Control
- Machine and Motion Control Devices
- Mass Storage Devices

### description

The TLV5623 is a 8-bit voltage output digital-to-analog converter (DAC) with a flexible 4-wire serial interface. The 4-wire serial interface allows glueless interface to TMS320, SPI, QSPI, and Microwire serial ports. The TLV5623 is programmed with a 16-bit serial string containing 4 control and 8 data bits. Developed for a wide range of supply voltages, the TLV5623 can operate from 2.7 V to 5.5 V.



The resistor string output voltage is buffered by a x2 gain rail-to-rail output buffer. The buffer features a Class AB output stage to improve stability and reduce settling time. The settling time of the DAC is programmable to allow the designer to optimize speed versus power dissipation. The settling time is chosen by the control bits within the 16-bit serial input string. A high-impedance buffer is integrated on the REFIN terminal to reduce the need for a low source impedance drive to the terminal.

Implemented with a CMOS process, the TLV5623 is designed for single supply operation from 2.7 V to 5.5 V. The device is available in an 8-terminal SOIC package. The TLV5623C is characterized for operation from 0°C to 70°C. The TLV5623I is characterized for operation from –40°C to 85°C.

### AVAILABLE OPTIONS

T <sub>A</sub>	PACKAGE	
	SMALL OUTLINE† (D)	MSOP (DGK)
0°C to 70°C	TLV5623CD	TLV5623CDGK
–40°C to 85°C	TLV5623ID	TLV5623IDGK

† Available in tape and reel as the TLV5623CDR and the TLV5623IDR



Please be aware that an important notice concerning availability, standard warranty, and use in critical applications of Texas Instruments semiconductor products and disclaimers thereto appears at the end of this data sheet.

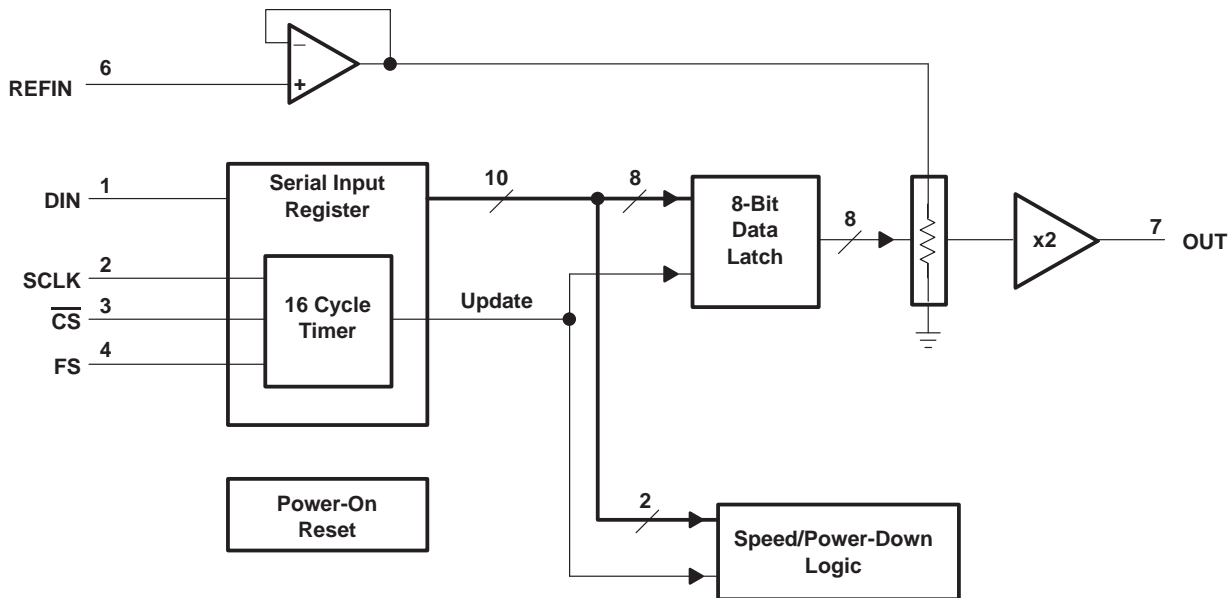
PRODUCTION DATA information is current as of publication date. Products conform to specifications per the terms of Texas Instruments standard warranty. Production processing does not necessarily include testing of all parameters.

# TLV5623C, TLV5623I

## 2.7-V TO 5.5-V LOW POWER 8-BIT DIGITAL-TO-ANALOG CONVERTERS WITH POWER DOWN

SLAS231B – JUNE 1999 – REVISED APRIL 2004

### functional block diagram



### Terminal Functions

TERMINAL NAME	NO.	I/O	DESCRIPTION
AGND	5		Analog ground
$\overline{CS}$	3	I	Chip select. Digital input used to enable and disable inputs, active low.
DIN	1	I	Serial digital data input
FS	4	I	Frame sync. Digital input used for 4-wire serial interfaces such as the TMS320 DSP interface.
OUT	7	O	DAC analog output
REFIN	6	I	Reference analog input voltage
SCLK	2	I	Serial digital clock input
V <sub>DD</sub>	8		Positive power supply

# TLV5623C, TLV5623I

## 2.7-V TO 5.5-V LOW POWER 8-BIT DIGITAL-TO-ANALOG CONVERTERS WITH POWER DOWN

SLAS231B – JUNE 1999 – REVISED APRIL 2004

### absolute maximum ratings over operating free-air temperature range (unless otherwise noted)†

Supply voltage ( $V_{DD}$ to AGND)	7 V
Reference input voltage range	– 0.3 V to $V_{DD} + 0.3$ V
Digital input voltage range	– 0.3 V to $V_{DD} + 0.3$ V
Operating free-air temperature range, $T_A$ : TLV5623C	0°C to 70°C
TLV5623I	–40°C to 85°C
Storage temperature range, $T_{stg}$	–65°C to 150°C
Lead temperature 1,6 mm (1/16 inch) from case for 10 seconds	260°C

† Stresses beyond those listed under “absolute maximum ratings” may cause permanent damage to the device. These are stress ratings only, and functional operation of the device at these or any other conditions beyond those indicated under “recommended operating conditions” is not implied. Exposure to absolute-maximum-rated conditions for extended periods may affect device reliability.

### recommended operating conditions

		MIN	NOM	MAX	UNIT
Supply voltage, $V_{DD}$	$V_{DD} = 5$ V	4.5	5	5.5	V
	$V_{DD} = 3$ V	2.7	3	3.3	V
High-level digital input voltage, $V_{IH}$	$DV_{DD} = 2.7$ V	2			V
	$DV_{DD} = 5.5$ V	2.4			V
Low-level digital input voltage, $V_{IL}$	$DV_{DD} = 2.7$ V			0.6	V
	$DV_{DD} = 5.5$ V			1	V
Reference voltage, $V_{ref}$ to REFIN terminal	$V_{DD} = 5$ V (see Note 1)	AGND	2.048	$V_{DD} - 1.5$	V
Reference voltage, $V_{ref}$ to REFIN terminal	$V_{DD} = 3$ V (see Note 1)	AGND	1.024	$V_{DD} - 1.5$	V
Load resistance, $R_L$		2	10		k $\Omega$
Load capacitance, $C_L$				100	pF
Clock frequency, $f_{CLK}$				20	MHz
Operating free-air temperature, $T_A$	TLV5623C	0		70	°C
	TLV5623I	–40		85	°C

NOTE 1: Due to the x2 output buffer, a reference input voltage  $\geq V_{DD}/2$  causes clipping of the transfer function.

### electrical characteristics over recommended operating free-air temperature range (unless otherwise noted)

#### power supply

PARAMETER		TEST CONDITIONS		MIN	TYP	MAX	UNIT
$I_{DD}$	Power supply current	$V_{DD} = 5$ V, $V_{REF} = 2.048$ V, No load, All inputs = AGND or $V_{DD}$ , DAC latch = 0x800	Fast		0.9	1.35	mA
			Slow		0.4	0.6	mA
		$V_{DD} = 3$ V, $V_{REF} = 1.024$ V, No load, All inputs = AGND or $V_{DD}$ , DAC latch = 0x800	Fast		0.7	1.1	mA
			Slow		0.3	0.45	mA
Power down supply current (see Figure 12)					1		$\mu$ A
PSRR	Power supply rejection ratio	Zero scale	See Note 2		–68		dB
		Full scale	See Note 3		–68		
Power on threshold voltage, POR					2		V

- NOTES: 2. Power supply rejection ratio at zero scale is measured by varying  $V_{DD}$  and is given by:  
 $PSRR = 20 \log [(E_{ZS}(V_{DDmax}) - E_{ZS}(V_{DDmin})) / V_{DDmax}]$
3. Power supply rejection ratio at full scale is measured by varying  $V_{DD}$  and is given by:  
 $PSRR = 20 \log [(E_G(V_{DDmax}) - E_G(V_{DDmin})) / V_{DDmax}]$

# TLV5623C, TLV5623I

## 2.7-V TO 5.5-V LOW POWER 8-BIT DIGITAL-TO-ANALOG CONVERTERS WITH POWER DOWN

SLAS231B – JUNE 1999 – REVISED APRIL 2004

electrical characteristics over recommended operating free-air temperature range (unless otherwise noted) (continued)

static DAC specifications  $R_L = 10\text{ k}\Omega$ ,  $C_L = 100\text{ pF}$

PARAMETER		TEST CONDITIONS	MIN	TYP	MAX	UNIT
Resolution			8			bits
INL	Integral nonlinearity	See Note 4		$\pm 0.3$	$\pm 0.5$	LSB
DNL	Differential nonlinearity	See Note 5		$\pm 0.07$	$\pm 0.2$	LSB
E <sub>ZS</sub>	Zero-scale error (offset error at zero scale)	See Note 6			$\pm 10$	mV
E <sub>ZS TC</sub>	Zero-scale-error temperature coefficient	See Note 7		10		ppm/°C
E <sub>G</sub>	Gain error	See Note 8			$\pm 0.6$	% of FS voltage
Gain-error temperature coefficient		See Note 9		10		ppm/°C

- NOTES: 4. The relative accuracy or integral nonlinearity (INL) sometimes referred to as linearity error, is the maximum deviation of the output from the line between zero and full scale excluding the effects of zero code and full-scale errors. Tested from code 10 to code 255.
5. The differential nonlinearity (DNL) sometimes referred to as differential error, is the difference between the measured and ideal 1 LSB amplitude change of any two adjacent codes. Monotonic means the output voltage changes in the same direction (or remains constant) as a change in the digital input code. Tested from code 10 to code 255.
6. Zero-scale error is the deviation from zero voltage output when the digital input code is zero.
7. Zero-scale-error temperature coefficient is given by:  $E_{ZS\ TC} = [E_{ZS}(T_{max}) - E_{ZS}(T_{min})]/V_{ref} \times 10^6/(T_{max} - T_{min})$ .
8. Gain error is the deviation from the ideal output ( $2V_{ref} - 1\text{ LSB}$ ) with an output load of  $10\text{ k}\Omega$  excluding the effects of the zero-error.
9. Gain temperature coefficient is given by:  $E_G\ TC = [E_G(T_{max}) - E_G(T_{min})]/V_{ref} \times 10^6/(T_{max} - T_{min})$ .

### output specifications

PARAMETER		TEST CONDITIONS	MIN	TYP	MAX	UNIT
V <sub>O</sub>	Voltage output range	$R_L = 10\text{ k}\Omega$	0		$V_{DD}-0.1$	V
Output load regulation accuracy		$R_L = 2\text{ k}\Omega$ , vs $10\text{ k}\Omega$		$\pm 0.1$	$\pm 0.25$	% of FS voltage

### reference input (REF)

PARAMETER		TEST CONDITIONS	MIN	TYP	MAX	UNIT
V <sub>I</sub>	Input voltage range		0		$V_{DD}-1.5$	V
R <sub>I</sub>	Input resistance			10		M $\Omega$
C <sub>I</sub>	Input capacitance			5		pF
Reference input bandwidth		REFIN = $0.2 V_{pp} + 1.024\text{ V dc}$	Slow		525	kHz
			Fast		1.3	MHz
Reference feed through		REFIN = $1 V_{pp}$ at $1\text{ kHz} + 1.024\text{ V dc}$ (see Note 10)		-75		dB

NOTE 10: Reference feedthrough is measured at the DAC output with an input code = 0x000.

### digital inputs

PARAMETER		TEST CONDITIONS	MIN	TYP	MAX	UNIT
I <sub>IH</sub>	High-level digital input current	$V_I = V_{DD}$			$\pm 1$	$\mu\text{A}$
I <sub>IL</sub>	Low-level digital input current	$V_I = 0\text{ V}$			$\pm 1$	$\mu\text{A}$
C <sub>I</sub>	Input capacitance			3		pF

**TLV5623C, TLV5623I**  
**2.7-V TO 5.5-V LOW POWER 8-BIT DIGITAL-TO-ANALOG**  
**CONVERTERS WITH POWER DOWN**

SLAS231B – JUNE 1999 – REVISED APRIL 2004

operating characteristics over recommended operating free-air temperature range (unless otherwise noted)

**analog output dynamic performance**

PARAMETER		TEST CONDITIONS		MIN	TYP	MAX	UNIT
$t_{s(FS)}$	Output settling time, full scale	$R_L = 10\text{ k}\Omega$ , See Note 11	$C_L = 100\text{ pF}$ ,	Fast	3	5.5	$\mu\text{s}$
				Slow	9	20	
$t_{s(CC)}$	Output settling time, code to code	$R_L = 10\text{ k}\Omega$ , See Note 12	$C_L = 100\text{ pF}$ ,	Fast	1		$\mu\text{s}$
				Slow	2		$\mu\text{s}$
SR	Slew rate	$R_L = 10\text{ k}\Omega$ , See Note 13	$C_L = 100\text{ pF}$ ,	Fast	3.6		$\text{V}/\mu\text{s}$
				Slow	0.9		
Glitch energy		Code transition from 0x7F0 to 0x800			10		$\text{nV}\text{-s}$
S/N	Signal to noise				57		dB
S/(N+D)	Signal to noise + distortion	$f_s = 400\text{ KSPS}$ $f_{out} = 1.1\text{ kHz}$ ,			49		dB
THD	Total harmonic distortion	$R_L = 10\text{ k}\Omega$ ,	$C_L = 100\text{ pF}$ ,		-50		dB
Spurious free dynamic range		BW = 20 kHz			60		dB

- NOTES: 11. Settling time is the time for the output signal to remain within  $\pm 0.5$  LSB of the final measured value for a digital input code change of 0x020 to 0xFF0 or 0xFF0 to 0x020. Not tested, ensured by design.  
12. Settling time is the time for the output signal to remain within  $\pm 0.5$  LSB of the final measured value for a digital input code change of one count. Not tested, ensured by design.  
13. Slew rate determines the time it takes for a change of the DAC output from 10% to 90% full-scale voltage.

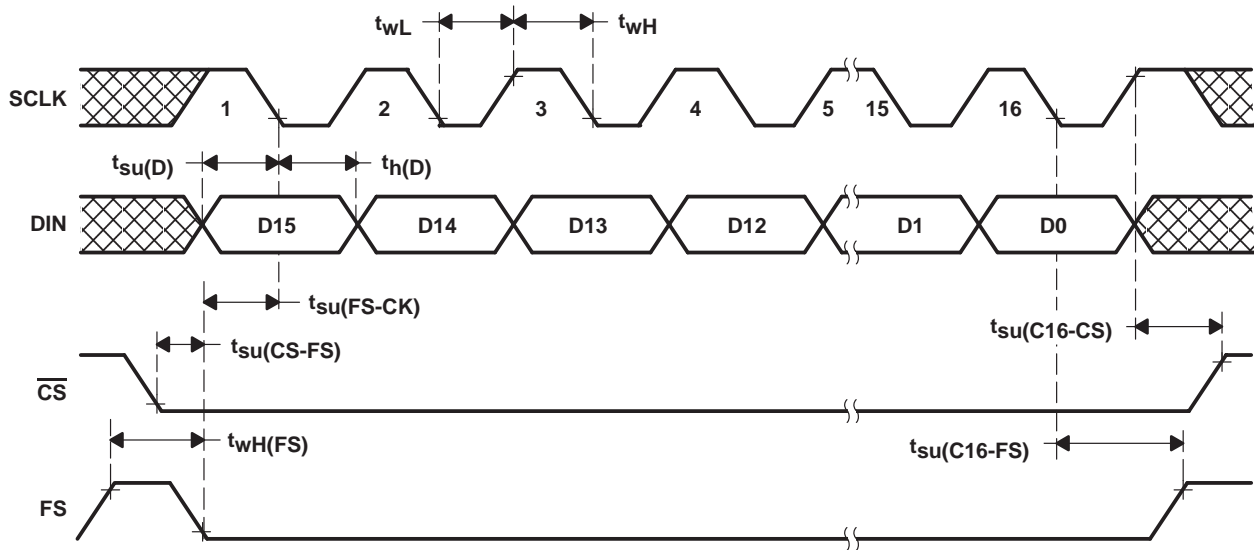
**digital input timing requirements**

		MIN	NOM	MAX	UNIT
$t_{su(CS-FS)}$	Setup time, $\overline{CS}$ low before $FS\downarrow$	10			ns
$t_{su(FS-CK)}$	Setup time, FS low before first negative SCLK edge	8			ns
$t_{su(C16-FS)}$	Setup time, sixteenth negative edge after FS low on which bit D0 is sampled before rising edge of FS	10			ns
$t_{su(C16-CS)}$	Setup time, sixteenth positive SCLK edge (first positive after D0 is sampled) before $\overline{CS}$ rising edge. If FS is used instead of the sixteenth positive edge to update the DAC, then the setup time is between the FS rising edge and CS rising edge.	10			ns
$t_{wH}$	Pulse duration, SCLK high	25			ns
$t_{wL}$	Pulse duration, SCLK low	25			ns
$t_{su(D)}$	Setup time, data ready before SCLK falling edge	8			ns
$t_h(D)$	Hold time, data held valid after SCLK falling edge	5			ns
$t_{wH(FS)}$	Pulse duration, FS high	20			ns

**TLV5623C, TLV5623I**  
**2.7-V TO 5.5-V LOW POWER 8-BIT DIGITAL-TO-ANALOG**  
**CONVERTERS WITH POWER DOWN**

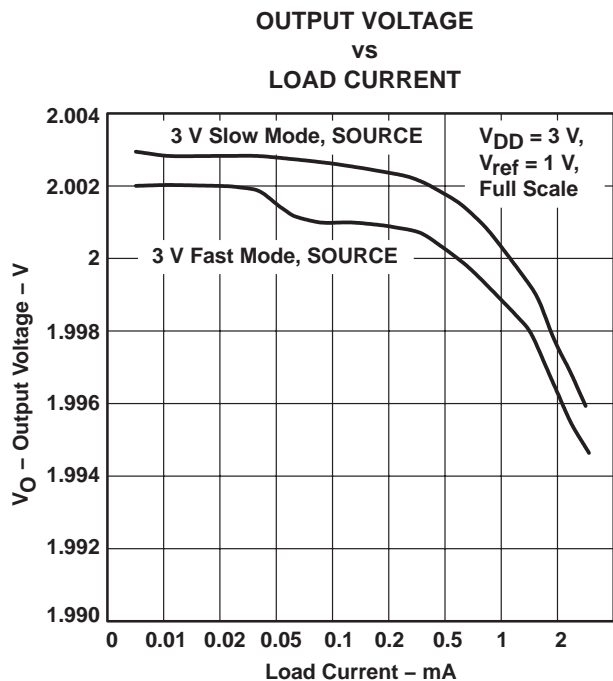
SLAS231B – JUNE 1999 – REVISED APRIL 2004

**PARAMETER MEASUREMENT INFORMATION**

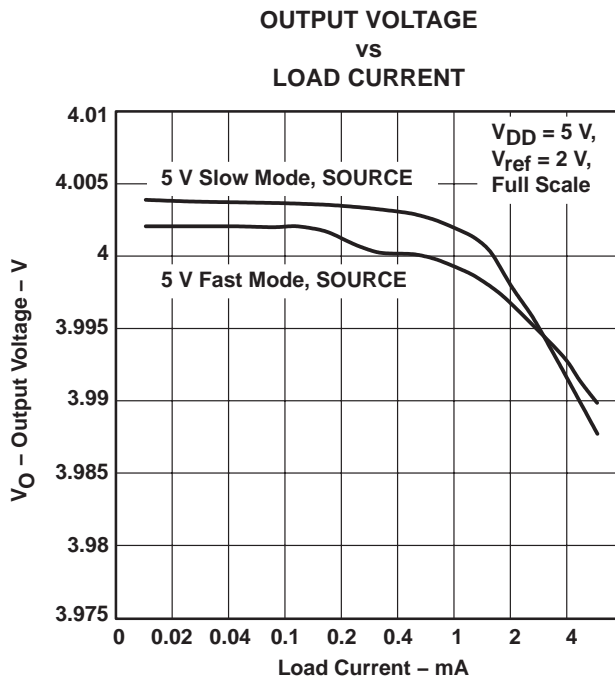


**Figure 1. Timing Diagram**

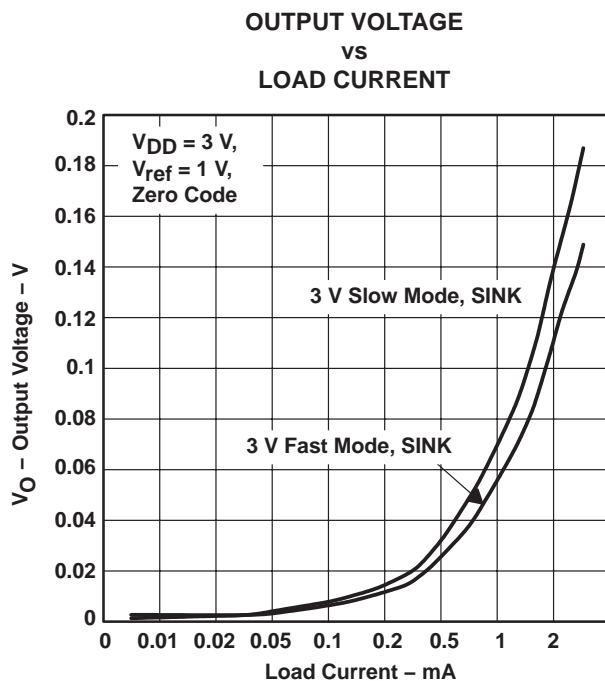
**TYPICAL CHARACTERISTICS**



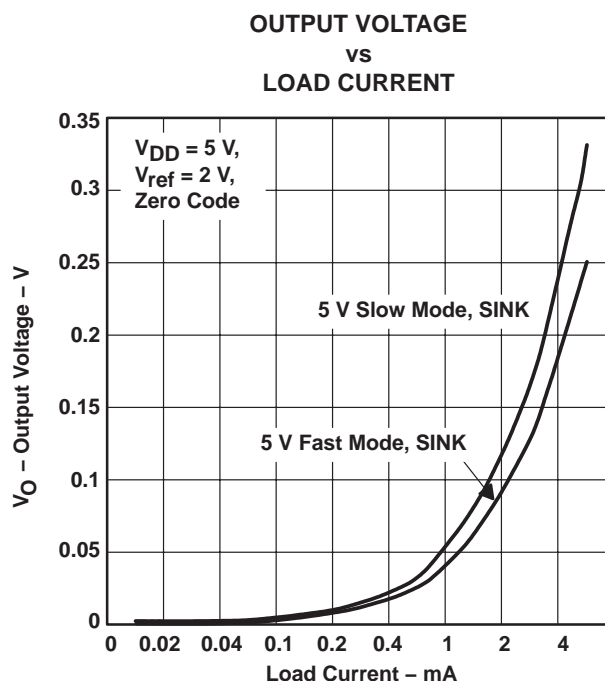
**Figure 2**



**Figure 3**



**Figure 4**



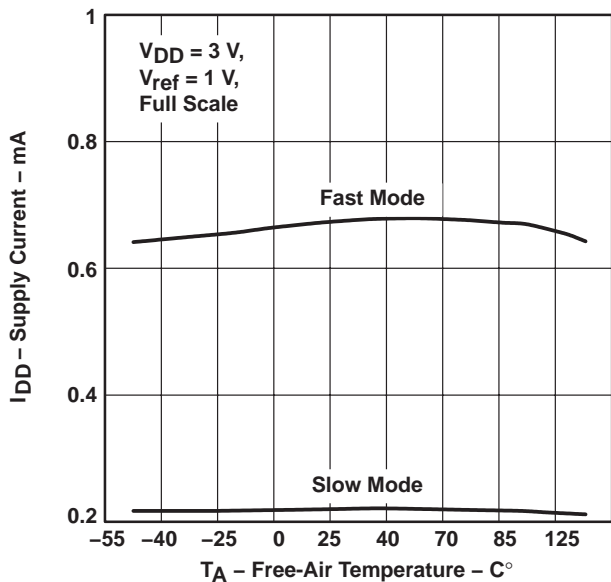
**Figure 5**

**TLV5623C, TLV5623I**  
**2.7-V TO 5.5-V LOW POWER 8-BIT DIGITAL-TO-ANALOG**  
**CONVERTERS WITH POWER DOWN**

SLAS231B – JUNE 1999 – REVISED APRIL 2004

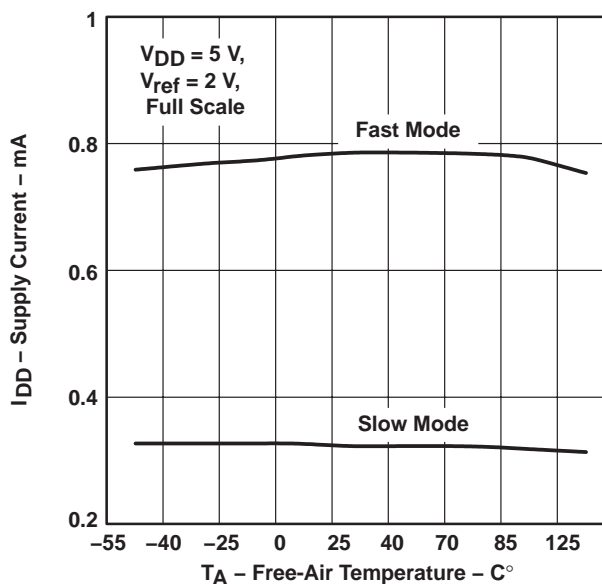
**TYPICAL CHARACTERISTICS**

**SUPPLY CURRENT**  
**vs**  
**FREE-AIR TEMPERATURE**



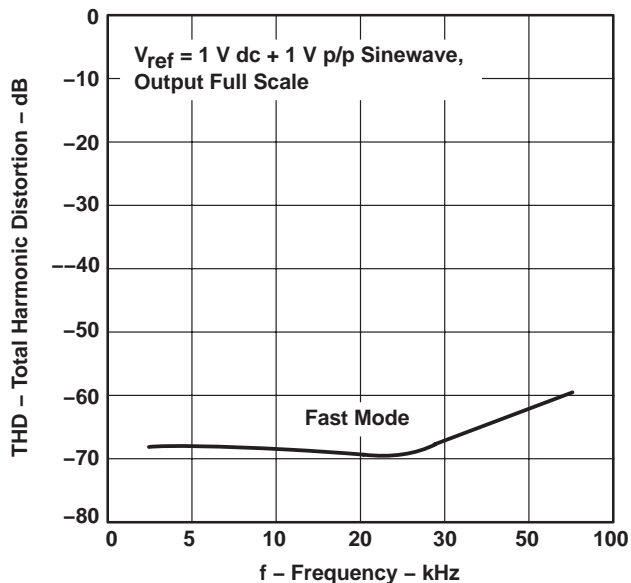
**Figure 6**

**SUPPLY CURRENT**  
**vs**  
**FREE-AIR TEMPERATURE**



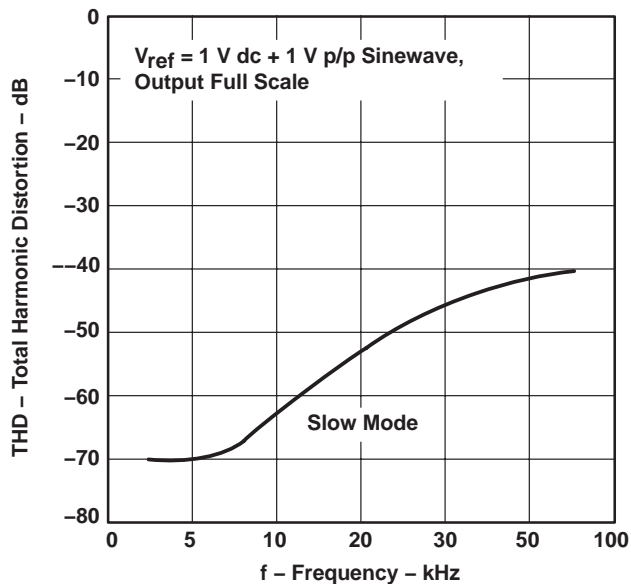
**Figure 7**

**TOTAL HARMONIC DISTORTION**  
**vs**  
**FREQUENCY**



**Figure 8**

**TOTAL HARMONIC DISTORTION**  
**vs**  
**FREQUENCY**



**Figure 9**



TYPICAL CHARACTERISTICS

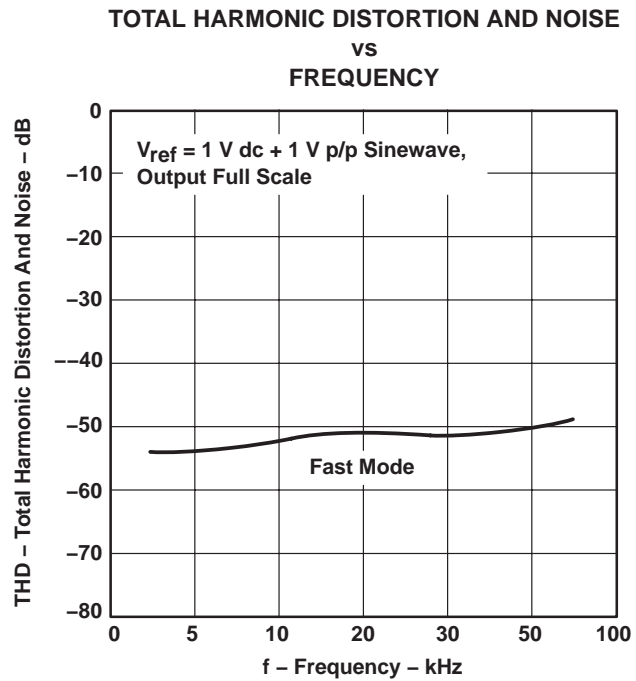


Figure 10

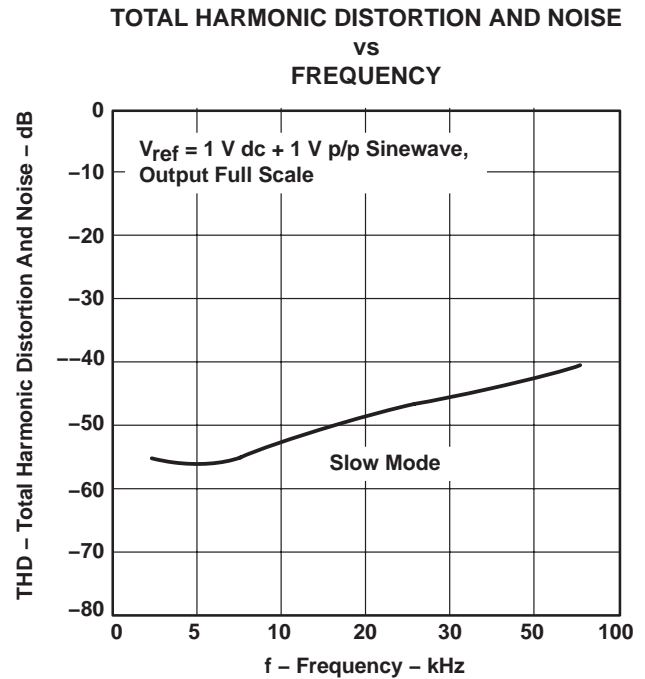


Figure 11

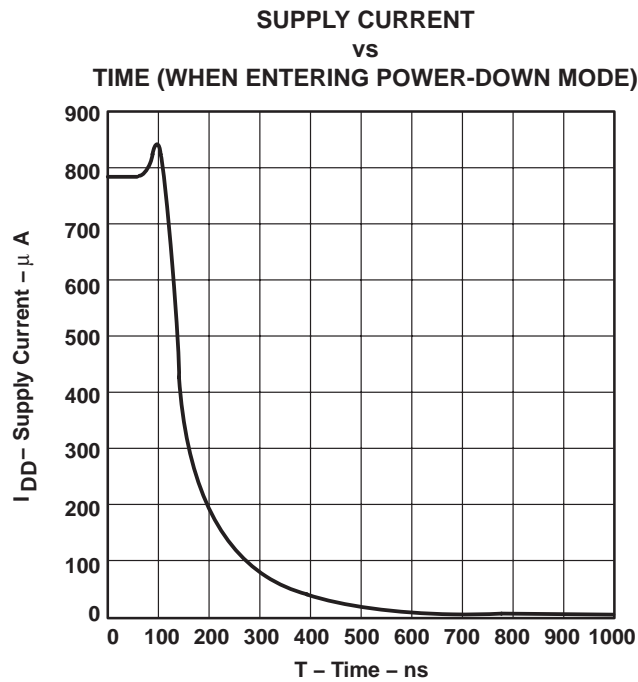


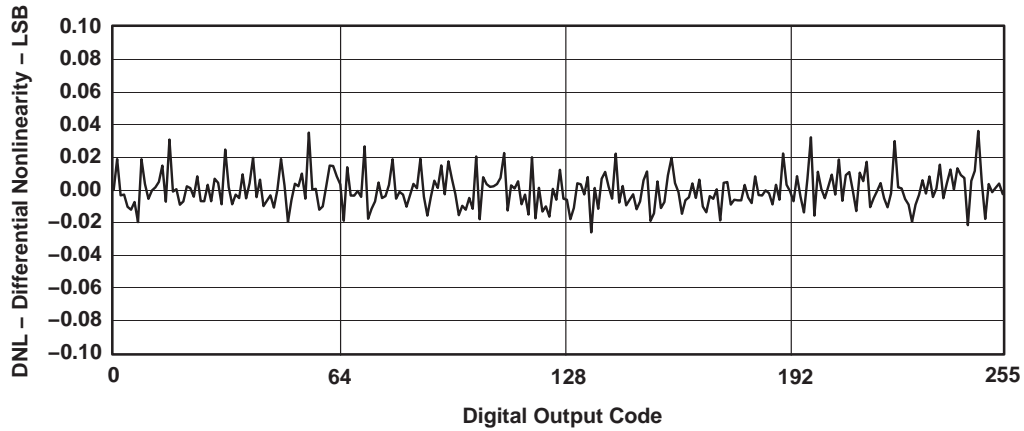
Figure 12

**TLV5623C, TLV5623I**  
**2.7-V TO 5.5-V LOW POWER 8-BIT DIGITAL-TO-ANALOG**  
**CONVERTERS WITH POWER DOWN**

SLAS231B – JUNE 1999 – REVISED APRIL 2004

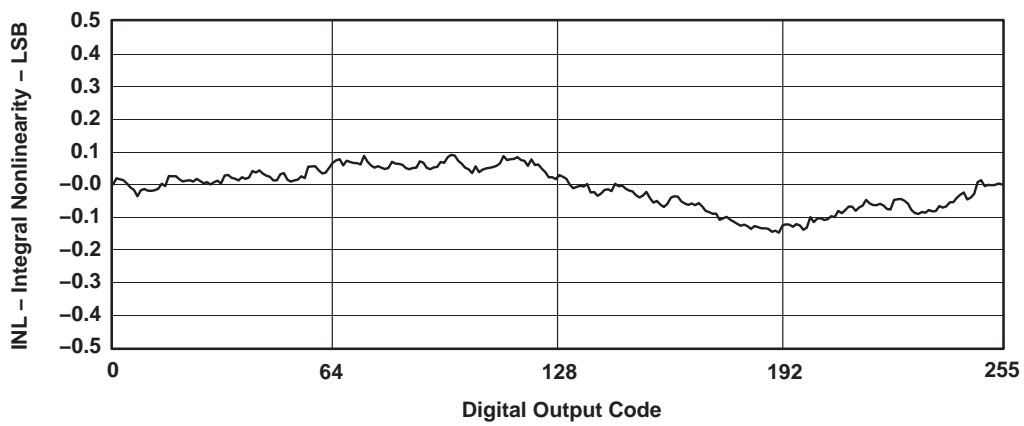
**TYPICAL CHARACTERISTICS**

**DIFFERENTIAL NONLINEARITY**  
**vs**  
**DIGITAL OUTPUT CODE**



**Figure 13**

**INTEGRAL NONLINEARITY**  
**vs**  
**DIGITAL OUTPUT CODE**



**Figure 14**

## APPLICATION INFORMATION

### general function

The TLV5623 is an 8-bit single supply DAC based on a resistor string architecture. The device consists of a serial interface, speed and power-down control logic, a reference input buffer, a resistor string, and a rail-to-rail output buffer.

The output voltage (full scale determined by external reference) is given by:

$$2 \text{ REF} \frac{\text{CODE}}{2^n} \text{ [V]}$$

where REF is the reference voltage and CODE is the digital input value within the range of  $0_{10}$  to  $2^n - 1$ , where  $n = 8$  (bits). The 16-bit data word, consisting of control bits and the new DAC value, is illustrated in the *data format* section. A power-on reset initially resets the internal latches to a defined state (all bits zero).

### serial interface

The device has to be enabled with  $\overline{\text{CS}}$  set to low. A falling edge of FS starts shifting the data bit-per-bit (starting with the MSB) to the internal register on the falling edges of SCLK. After 16 bits have been transferred or FS rises, the content of the shift register is moved to the DAC latch, which updates the voltage output to the new level.

The serial interface of the TLV5623 can be used in two basic modes:

- Four wire (with chip select)
- Three wire (without chip select)

Using chip select (four-wire mode), it is possible to have more than one device connected to the serial port of the data source (DSP or microcontroller). The interface is compatible with the TMS320 family. Figure 15 shows an example with two TLV5623s connected directly to a TMS320 DSP.

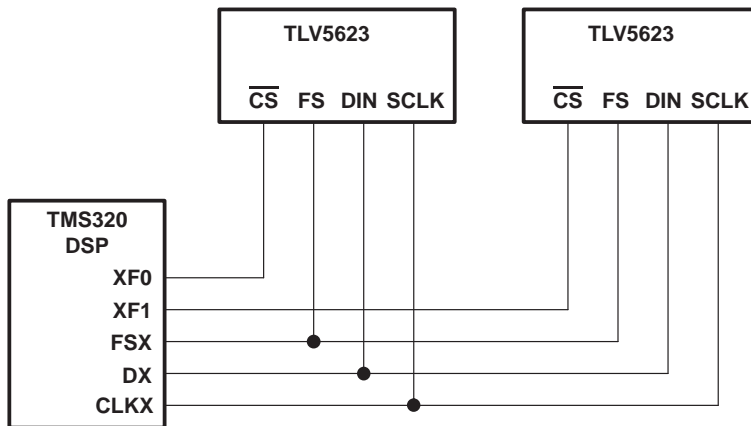


Figure 15. TMS320 Interface

# TLV5623C, TLV5623I

## 2.7-V TO 5.5-V LOW POWER 8-BIT DIGITAL-TO-ANALOG CONVERTERS WITH POWER DOWN

SLAS231B – JUNE 1999 – REVISED APRIL 2004

### APPLICATION INFORMATION

#### serial interface (continued)

If there is no need to have more than one device on the serial bus, then  $\overline{CS}$  can be tied low. Figure 16 shows an example of how to connect the TLV5623 to a TMS320, SPI, or Microwire port using only three pins.

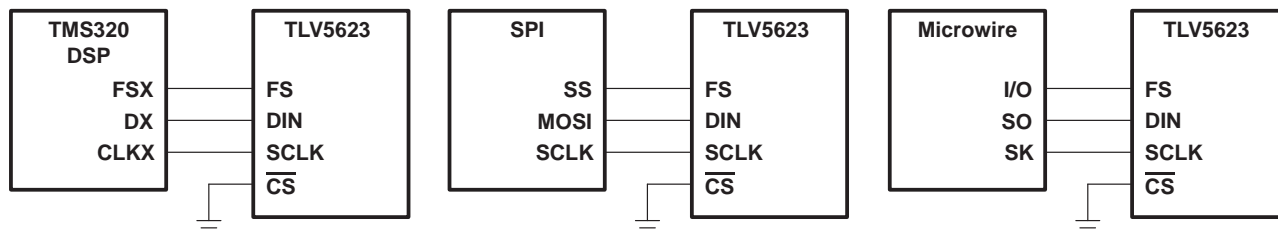


Figure 16. Three-Wire Interface

Notes on SPI and Microwire: Before the controller starts the data transfer, the software has to generate a falling edge on the I/O pin connected to FS. If the word width is 8 bits (SPI and Microwire), two write operations must be performed to program the TLV5623. After the write operation(s), the DAC output is updated automatically on the next positive clock edge following the sixteenth falling clock edge.

#### serial clock frequency and update rate

The maximum serial clock frequency is given by:

$$f_{SCLKmax} = \frac{1}{t_{wH(min)} + t_{wL(min)}} = 20 \text{ MHz}$$

The maximum update rate is:

$$f_{UPDATEmax} = \frac{1}{16(t_{wH(min)} + t_{wL(min)})} = 1.25 \text{ MHz}$$

The maximum update rate is a theoretical value for the serial interface, since the settling time of the TLV5623 has to be considered also.

#### data format

The 16-bit data word for the TLV5623 consists of two parts:

- Control bits (D15 . . . D12)
- New DAC value (D11 . . . D0)

D15	D14	D13	D12	D11	D10	D9	D8	D7	D6	D5	D4	D3	D2	D1	D0
X	SPD	PWR	X	New DAC value (8 bits)								0	0	0	0

X: don't care

SPD: Speed control bit. 1 → fast mode 0 → slow mode

PWR: Power control bit. 1 → power down 0 → normal operation

In power-down mode, all amplifiers within the TLV5623 are disabled.

## APPLICATION INFORMATION

### TLV5623 interfaced to TMS320C203 DSP

#### hardware interfacing

Figure 17 shows an example how to connect the TLV5623 to a TMS320C203 DSP. The serial interface of the TLV5623 is ideally suited to this configuration, using a maximum of four wires to make the necessary connections. In applications where only one synchronous serial peripheral is used, the interface can be simplified even further by pulling  $\overline{CS}$  low all the time as shown in the figure.

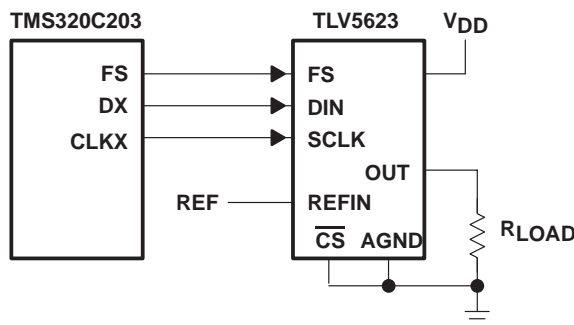


Figure 17. TLV5623 to DSP Interface

### TLV5623 interfaced to MCS51<sup>®</sup> microcontroller

#### hardware interfacing

Figure 18 shows an example of how to connect the TLV5623 to an MCS51<sup>®</sup> compatible microcontroller. The serial DAC input data and external control signals are sent via I/O port 3 of the controller. The serial data is sent on the RxD line, with the serial clock output on the TxD line. P3.4 and P3.5 are configured as outputs to provide the chip select and frame sync signals for the TLV5623.

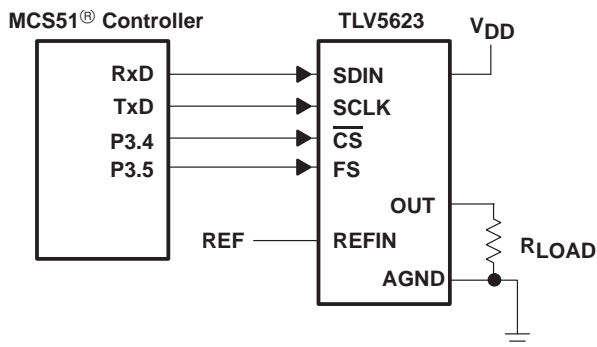


Figure 18. TLV5623 to MCS51<sup>®</sup> Controller Interface

# TLV5623C, TLV5623I

## 2.7-V TO 5.5-V LOW POWER 8-BIT DIGITAL-TO-ANALOG CONVERTERS WITH POWER DOWN

SLAS231B – JUNE 1999 – REVISED APRIL 2004

### APPLICATION INFORMATION

#### linearity, offset, and gain error using single ended supplies

When an amplifier is operated from a single supply, the voltage offset can still be either positive or negative. With a positive offset, the output voltage changes on the first code change. With a negative offset, the output voltage may not change with the first code, depending on the magnitude of the offset voltage.

The output amplifier attempts to drive the output to a negative voltage. However, because the most negative supply rail is ground, the output cannot drive below ground and clamps the output at 0 V.

The output voltage then remains at zero until the input code value produces a sufficient positive output voltage to overcome the negative offset voltage, resulting in the transfer function shown in Figure 19.

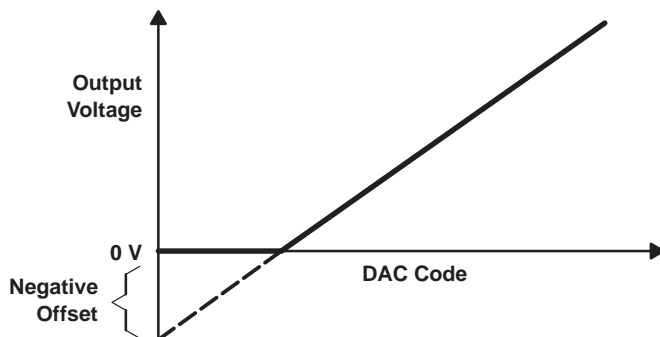


Figure 19. Effect of Negative Offset (single supply)

This offset error, not the linearity error, produces this breakpoint. The transfer function would have followed the dotted line if the output buffer could drive below the ground rail.

For a DAC, linearity is measured between zero-input code (all inputs 0) and full-scale code after offset and full scale are adjusted out or accounted for in some way. However, single supply operation does not allow for adjustment when the offset is negative due to the breakpoint in the transfer function. So the linearity is measured between full-scale code and the lowest code that produces a positive output voltage.

#### power-supply bypassing and ground management

Printed-circuit boards that use separate analog and digital ground planes offer the best system performance. Wire-wrap boards do not perform well and should not be used. The two ground planes should be connected together at the low-impedance power-supply source. The best ground connection may be achieved by connecting the DAC AGND terminal to the system analog ground plane, making sure that analog ground currents are well managed and there are negligible voltage drops across the ground plane.

A 0.1- $\mu$ F ceramic-capacitor bypass should be connected between  $V_{DD}$  and AGND and mounted with short leads as close as possible to the device. Use of ferrite beads may further isolate the system analog supply from the digital power supply.

Figure 20 shows the ground plane layout and bypassing technique.

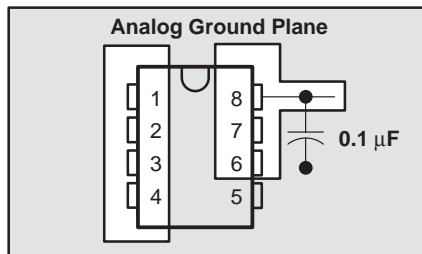


Figure 20. Power-Supply Bypassing

---

## APPLICATION INFORMATION

### definitions of specifications and terminology

#### integral nonlinearity (INL)

The relative accuracy or integral nonlinearity (INL), sometimes referred to as linearity error, is the maximum deviation of the output from the line between zero and full scale excluding the effects of zero code and full-scale errors.

#### differential nonlinearity (DNL)

The differential nonlinearity (DNL), sometimes referred to as differential error, is the difference between the measured and ideal 1 LSB amplitude change of any two adjacent codes. Monotonic means the output voltage changes in the same direction (or remains constant) as a change in the digital input code.

#### zero-scale error ( $E_{ZS}$ )

Zero-scale error is defined as the deviation of the output from 0 V at a digital input value of 0.

#### gain error ( $E_G$ )

Gain error is the error in slope of the DAC transfer function.

#### signal-to-noise ratio + distortion (S/N+D)

S/N+D is the ratio of the rms value of the output signal to the rms sum of all other spectral components below the Nyquist frequency, including harmonics but excluding dc. The value for S/N+D is expressed in decibels.

#### spurious free dynamic range (SFDR)

SFDR is the difference between the rms value of the output signal and the rms value of the largest spurious signal within a specified bandwidth. The value for SFDR is expressed in decibels.

#### total harmonic distortion (THD)

THD is the ratio of the rms sum of the first six harmonic components to the rms value of the fundamental signal and is expressed in decibels.

**PACKAGING INFORMATION**

Orderable Device	Status <sup>(1)</sup>	Package Type	Package Drawing	Pins	Package Qty	Eco Plan <sup>(2)</sup>	Lead/Ball Finish	MSL Peak Temp <sup>(3)</sup>
TLV5623CD	ACTIVE	SOIC	D	8	75	Green (RoHS & no Sb/Br)	CU NIPDAU	Level-1-260C-UNLIM
TLV5623CDG4	ACTIVE	SOIC	D	8	75	Green (RoHS & no Sb/Br)	CU NIPDAU	Level-1-260C-UNLIM
TLV5623CDGK	ACTIVE	MSOP	DGK	8	80	Green (RoHS & no Sb/Br)	CU NIPDAU	Level-1-260C-UNLIM
TLV5623CDGKG4	ACTIVE	MSOP	DGK	8	80	Green (RoHS & no Sb/Br)	CU NIPDAU	Level-1-260C-UNLIM
TLV5623CDGKR	ACTIVE	MSOP	DGK	8	2500	Green (RoHS & no Sb/Br)	CU NIPDAU	Level-1-260C-UNLIM
TLV5623CDGKRG4	ACTIVE	MSOP	DGK	8	2500	Green (RoHS & no Sb/Br)	CU NIPDAU	Level-1-260C-UNLIM
TLV5623CDR	ACTIVE	SOIC	D	8	2500	Green (RoHS & no Sb/Br)	CU NIPDAU	Level-1-260C-UNLIM
TLV5623CDRG4	ACTIVE	SOIC	D	8	2500	Green (RoHS & no Sb/Br)	CU NIPDAU	Level-1-260C-UNLIM
TLV5623ID	ACTIVE	SOIC	D	8	75	Green (RoHS & no Sb/Br)	CU NIPDAU	Level-1-260C-UNLIM
TLV5623IDG4	ACTIVE	SOIC	D	8	75	Green (RoHS & no Sb/Br)	CU NIPDAU	Level-1-260C-UNLIM
TLV5623IDGK	ACTIVE	MSOP	DGK	8	80	Green (RoHS & no Sb/Br)	CU NIPDAU	Level-1-260C-UNLIM
TLV5623IDGKG4	ACTIVE	MSOP	DGK	8	80	Green (RoHS & no Sb/Br)	CU NIPDAU	Level-1-260C-UNLIM
TLV5623IDGKR	ACTIVE	MSOP	DGK	8	2500	Green (RoHS & no Sb/Br)	CU NIPDAU	Level-1-260C-UNLIM
TLV5623IDGKRG4	ACTIVE	MSOP	DGK	8	2500	Green (RoHS & no Sb/Br)	CU NIPDAU	Level-1-260C-UNLIM
TLV5623IDR	ACTIVE	SOIC	D	8	2500	Green (RoHS & no Sb/Br)	CU NIPDAU	Level-1-260C-UNLIM
TLV5623IDRG4	ACTIVE	SOIC	D	8	2500	Green (RoHS & no Sb/Br)	CU NIPDAU	Level-1-260C-UNLIM

<sup>(1)</sup> The marketing status values are defined as follows:

**ACTIVE:** Product device recommended for new designs.

**LIFEBUY:** TI has announced that the device will be discontinued, and a lifetime-buy period is in effect.

**NRND:** Not recommended for new designs. Device is in production to support existing customers, but TI does not recommend using this part in a new design.

**PREVIEW:** Device has been announced but is not in production. Samples may or may not be available.

**OBSOLETE:** TI has discontinued the production of the device.

<sup>(2)</sup> Eco Plan - The planned eco-friendly classification: Pb-Free (RoHS), Pb-Free (RoHS Exempt), or Green (RoHS & no Sb/Br) - please check <http://www.ti.com/productcontent> for the latest availability information and additional product content details.

**TBD:** The Pb-Free/Green conversion plan has not been defined.

**Pb-Free (RoHS):** TI's terms "Lead-Free" or "Pb-Free" mean semiconductor products that are compatible with the current RoHS requirements for all 6 substances, including the requirement that lead not exceed 0.1% by weight in homogeneous materials. Where designed to be soldered at high temperatures, TI Pb-Free products are suitable for use in specified lead-free processes.

**Pb-Free (RoHS Exempt):** This component has a RoHS exemption for either 1) lead-based flip-chip solder bumps used between the die and package, or 2) lead-based die adhesive used between the die and leadframe. The component is otherwise considered Pb-Free (RoHS compatible) as defined above.

**Green (RoHS & no Sb/Br):** TI defines "Green" to mean Pb-Free (RoHS compatible), and free of Bromine (Br) and Antimony (Sb) based flame retardants (Br or Sb do not exceed 0.1% by weight in homogeneous material)



<sup>(3)</sup> MSL, Peak Temp. -- The Moisture Sensitivity Level rating according to the JEDEC industry standard classifications, and peak solder temperature.

**Important Information and Disclaimer:**The information provided on this page represents TI's knowledge and belief as of the date that it is provided. TI bases its knowledge and belief on information provided by third parties, and makes no representation or warranty as to the accuracy of such information. Efforts are underway to better integrate information from third parties. TI has taken and continues to take reasonable steps to provide representative and accurate information but may not have conducted destructive testing or chemical analysis on incoming materials and chemicals. TI and TI suppliers consider certain information to be proprietary, and thus CAS numbers and other limited information may not be available for release.

In no event shall TI's liability arising out of such information exceed the total purchase price of the TI part(s) at issue in this document sold by TI to Customer on an annual basis.

**TAPE AND REEL INFORMATION**



**QUADRANT ASSIGNMENTS FOR PIN 1 ORIENTATION IN TAPE**



\*All dimensions are nominal

Device	Package Type	Package Drawing	Pins	SPQ	Reel Diameter (mm)	Reel Width W1 (mm)	A0 (mm)	B0 (mm)	K0 (mm)	P1 (mm)	W (mm)	Pin1 Quadrant
TLV5623CDGKR	MSOP	DGK	8	2500	330.0	12.4	5.3	3.4	1.4	8.0	12.0	Q1
TLV5623CDR	SOIC	D	8	2500	330.0	12.4	6.4	5.2	2.1	8.0	12.0	Q1
TLV5623IDGKR	MSOP	DGK	8	2500	330.0	12.4	5.3	3.4	1.4	8.0	12.0	Q1
TLV5623IDR	SOIC	D	8	2500	330.0	12.4	6.4	5.2	2.1	8.0	12.0	Q1

**TAPE AND REEL BOX DIMENSIONS**

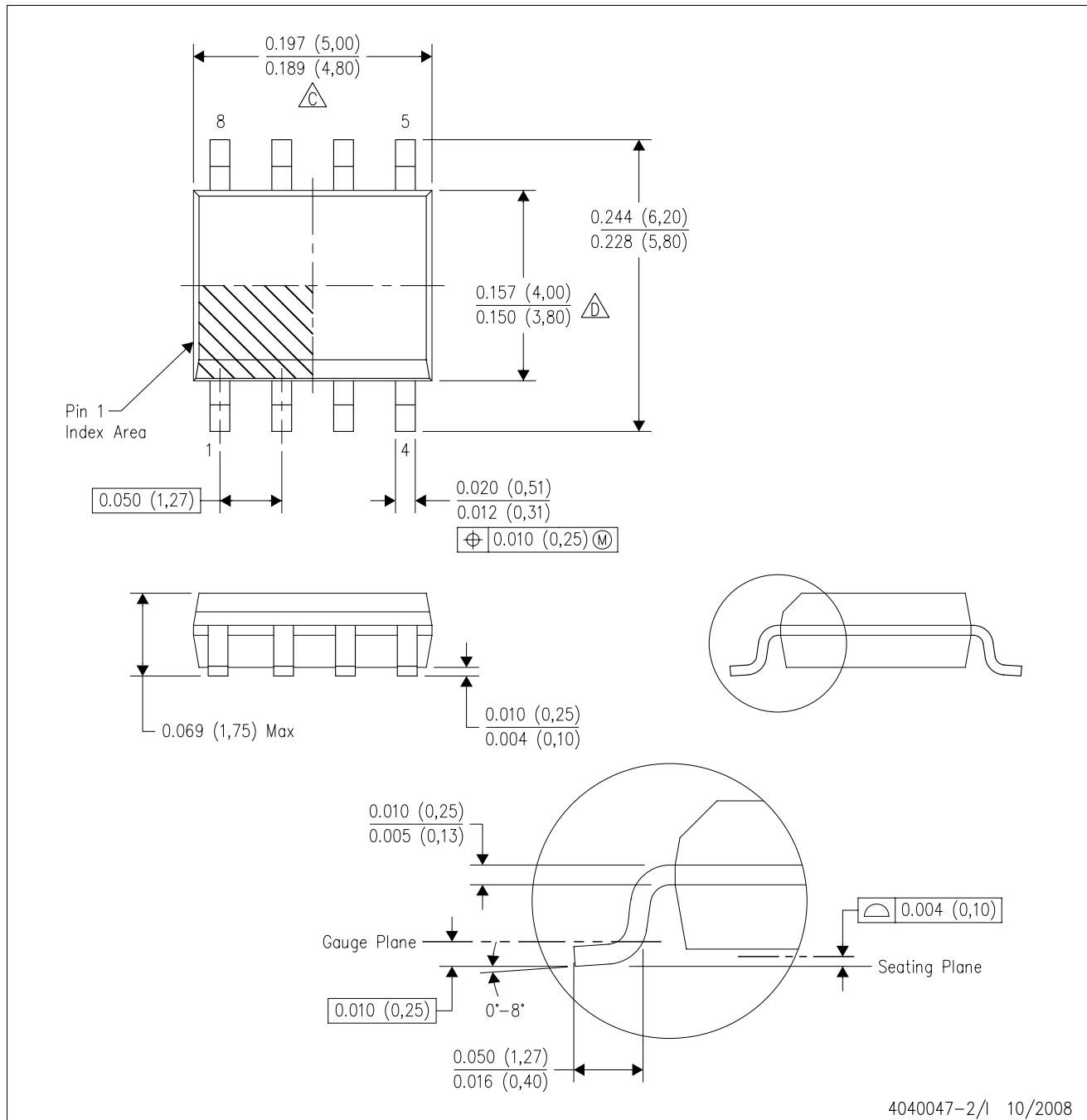


\*All dimensions are nominal

Device	Package Type	Package Drawing	Pins	SPQ	Length (mm)	Width (mm)	Height (mm)
TLV5623CDGKR	MSOP	DGK	8	2500	346.0	346.0	29.0
TLV5623CDR	SOIC	D	8	2500	346.0	346.0	29.0
TLV5623IDGKR	MSOP	DGK	8	2500	346.0	346.0	29.0
TLV5623IDR	SOIC	D	8	2500	346.0	346.0	29.0

D (R-PDSO-G8)

PLASTIC SMALL-OUTLINE PACKAGE



- NOTES:
- A. All linear dimensions are in inches (millimeters).
  - B. This drawing is subject to change without notice.
  - C. Body length does not include mold flash, protrusions, or gate burrs. Mold flash, protrusions, or gate burrs shall not exceed .006 (0,15) per end.
  - D. Body width does not include interlead flash. Interlead flash shall not exceed .017 (0,43) per side.
  - E. Reference JEDEC MS-012 variation AA.

DGK (S-PDSO-G8)

PLASTIC SMALL-OUTLINE PACKAGE



- NOTES:
- A. All linear dimensions are in millimeters.
  - B. This drawing is subject to change without notice.
  - C. Body length does not include mold flash, protrusions, or gate burrs. Mold flash, protrusions, or gate burrs shall not exceed 0.15 per end.
  - D. Body width does not include interlead flash. Interlead flash shall not exceed 0.50 per side.
  - E. Falls within JEDEC MO-187 variation AA, except interlead flash.

## IMPORTANT NOTICE

Texas Instruments Incorporated and its subsidiaries (TI) reserve the right to make corrections, modifications, enhancements, improvements, and other changes to its products and services at any time and to discontinue any product or service without notice. Customers should obtain the latest relevant information before placing orders and should verify that such information is current and complete. All products are sold subject to TI's terms and conditions of sale supplied at the time of order acknowledgment.

TI warrants performance of its hardware products to the specifications applicable at the time of sale in accordance with TI's standard warranty. Testing and other quality control techniques are used to the extent TI deems necessary to support this warranty. Except where mandated by government requirements, testing of all parameters of each product is not necessarily performed.

TI assumes no liability for applications assistance or customer product design. Customers are responsible for their products and applications using TI components. To minimize the risks associated with customer products and applications, customers should provide adequate design and operating safeguards.

TI does not warrant or represent that any license, either express or implied, is granted under any TI patent right, copyright, mask work right, or other TI intellectual property right relating to any combination, machine, or process in which TI products or services are used. Information published by TI regarding third-party products or services does not constitute a license from TI to use such products or services or a warranty or endorsement thereof. Use of such information may require a license from a third party under the patents or other intellectual property of the third party, or a license from TI under the patents or other intellectual property of TI.

Reproduction of TI information in TI data books or data sheets is permissible only if reproduction is without alteration and is accompanied by all associated warranties, conditions, limitations, and notices. Reproduction of this information with alteration is an unfair and deceptive business practice. TI is not responsible or liable for such altered documentation. Information of third parties may be subject to additional restrictions.

Resale of TI products or services with statements different from or beyond the parameters stated by TI for that product or service voids all express and any implied warranties for the associated TI product or service and is an unfair and deceptive business practice. TI is not responsible or liable for any such statements.

TI products are not authorized for use in safety-critical applications (such as life support) where a failure of the TI product would reasonably be expected to cause severe personal injury or death, unless officers of the parties have executed an agreement specifically governing such use. Buyers represent that they have all necessary expertise in the safety and regulatory ramifications of their applications, and acknowledge and agree that they are solely responsible for all legal, regulatory and safety-related requirements concerning their products and any use of TI products in such safety-critical applications, notwithstanding any applications-related information or support that may be provided by TI. Further, Buyers must fully indemnify TI and its representatives against any damages arising out of the use of TI products in such safety-critical applications.

TI products are neither designed nor intended for use in military/aerospace applications or environments unless the TI products are specifically designated by TI as military-grade or "enhanced plastic." Only products designated by TI as military-grade meet military specifications. Buyers acknowledge and agree that any such use of TI products which TI has not designated as military-grade is solely at the Buyer's risk, and that they are solely responsible for compliance with all legal and regulatory requirements in connection with such use.

TI products are neither designed nor intended for use in automotive applications or environments unless the specific TI products are designated by TI as compliant with ISO/TS 16949 requirements. Buyers acknowledge and agree that, if they use any non-designated products in automotive applications, TI will not be responsible for any failure to meet such requirements.

Following are URLs where you can obtain information on other Texas Instruments products and application solutions:

### Products

Amplifiers	<a href="http://amplifier.ti.com">amplifier.ti.com</a>
Data Converters	<a href="http://dataconverter.ti.com">dataconverter.ti.com</a>
DSP	<a href="http://dsp.ti.com">dsp.ti.com</a>
Clocks and Timers	<a href="http://www.ti.com/clocks">www.ti.com/clocks</a>
Interface	<a href="http://interface.ti.com">interface.ti.com</a>
Logic	<a href="http://logic.ti.com">logic.ti.com</a>
Power Mgmt	<a href="http://power.ti.com">power.ti.com</a>
Microcontrollers	<a href="http://microcontroller.ti.com">microcontroller.ti.com</a>
RFID	<a href="http://www.ti-rfid.com">www.ti-rfid.com</a>
RF/IF and ZigBee® Solutions	<a href="http://www.ti.com/lprf">www.ti.com/lprf</a>

### Applications

Audio	<a href="http://www.ti.com/audio">www.ti.com/audio</a>
Automotive	<a href="http://www.ti.com/automotive">www.ti.com/automotive</a>
Broadband	<a href="http://www.ti.com/broadband">www.ti.com/broadband</a>
Digital Control	<a href="http://www.ti.com/digitalcontrol">www.ti.com/digitalcontrol</a>
Medical	<a href="http://www.ti.com/medical">www.ti.com/medical</a>
Military	<a href="http://www.ti.com/military">www.ti.com/military</a>
Optical Networking	<a href="http://www.ti.com/opticalnetwork">www.ti.com/opticalnetwork</a>
Security	<a href="http://www.ti.com/security">www.ti.com/security</a>
Telephony	<a href="http://www.ti.com/telephony">www.ti.com/telephony</a>
Video & Imaging	<a href="http://www.ti.com/video">www.ti.com/video</a>
Wireless	<a href="http://www.ti.com/wireless">www.ti.com/wireless</a>

Mailing Address: Texas Instruments, Post Office Box 655303, Dallas, Texas 75265  
Copyright © 2008, Texas Instruments Incorporated